

## TIMING OPERATIONS AND DATA PROCESSING IN THE GODDARD LASER TRACKING NETWORK

A. Clinton, E. Detoma, W. Hanrahan, P. Kushmeider  
Bendix Field Engineering Corporation  
Columbia, Md. 21045

### ABSTRACT

The NASA Crustal Dynamics Project has deployed Satellite Ranging (SLR) systems and Very Long Baseline Interferometer (VLBI) systems for measurements of global and regional crustal motions and earth rotational parameters. As part of this effort, Bendix Field Engineering Corporation (BFEC) is currently providing engineering and technical support in operations, data collection and data reduction and analysis for NASA's Crustal Dynamics Project.

NASA Laser ranging systems are used to determine the range to a target satellite by measuring the flight time of a short pulse of intense light to the target and back. The ranging data can be used for determining satellite orbital parameters, polar motion, earth tidal parameters and the distance between laser ranging system sites.

The accuracy of laser ranging is critically dependent upon precise timing. BFEC's current requirements are to maintain synchronization between laser stations, and reference them back to UTC(USNO), to within  $\pm 1.0$  microsecond, with the potential to meet a few hundred nanosecond requirement in the near future.

This paper will present the activities and procedures which are used to meet the aforementioned requirements and also, the efforts which are underway at BFEC to improve present performance. The Precision Timing Section (PTS) at BFEC has been responsible for maintaining and reporting time positions for the Goddard Laser Tracking Network (GLTN) for the past twelve years. GLTN's stringent timing requirements have necessitated the development and utilization of advance time transfer and timing data processing techniques. New timing equipment and methods are being tested and developed by PTS to increase BFEC's capabilities in time generation and time synchronization, in close cooperation with NASA and other U.S. government agencies.

### INTRODUCTION

The NASA Crustal Dynamics Project has deployed Satellite Laser Ranging (SLR) systems and Very Long Baseline Interferometer (VLBI) systems for measurement of global and regional crustal motions and Earth rotation parameters. As part of this effort, the Bendix Field Engineering Corporation (BFEC) is currently providing engineering and technical support in operations, data collection, data reduction and analysis for NASA's Crustal Dynamics Project.

NASA Laser Ranging systems are used to determine the range to a target satellite by measuring the flight time of a short pulse of light to the target and back. The ranging data can be used for determining satellite orbital parameters, Earth polar motion, tidal parameters and the distance between Laser ranging system sites.

The accuracy of Laser ranging is critically dependent upon precise timing: this paper presents the activities and the procedures which are used to meet the Laser Network requirements and the efforts which are underway at BFEC to improve the present performance.

## IMPACT OF TIMING ON RANGING PERFORMANCES

Precise Laser ranging to an Earth satellite imposes severe requirements for the reference time and frequency standard oscillator; in particular:

- the short term stability of the oscillator affects the ranging precision and ranging accuracy is critically dependent upon its frequency accuracy;
- time synchronization is very important and directly affects the error in the determination of the baseline length between ranging stations, because the correlation of measurements taken at different sites with the satellite position is performed by time-tagging the range measurements performed at each site.

The accuracy limitations to the two-way ranging of an artificial satellite due to instabilities of the reference oscillator at the tracking station are well known, and this problem has been extensively discussed in the literature<sup>[1]</sup>.

The range measurement is commonly performed by transmitting a short pulse of light to the satellite, where corner cube reflectors reflect the signal back to the ground station; the station is able to measure the round-trip delay  $T$ , from which the distance  $D$ , travelled by the pulse, can be easily computed when the speed of propagation  $c$  is known:

$$(1) \quad D = cT$$

The time delay  $T$ , is measured using the local stations oscillator frequency as a reference, and any offset or instability in the frequency of the reference oscillator will translate immediately into an error on  $D$ . Since the frequency fluctuation  $\Delta f$ , around the nominal frequency  $f$  results in a  $\Delta T$  fluctuation over an arbitrary time interval  $T$ :

$$(2) \quad \frac{\Delta f}{f} = \frac{\Delta T}{T}$$

the uncertainty  $\Delta r$  on the range measurement  $r$  (where  $r = D/2$ ) can be written as:

$$(3) \quad \Delta r = \frac{cT}{2} \frac{\Delta f}{f}$$

The nominal oscillator accuracy for commercial Cesium beam frequency standard<sup>[2]</sup> is very high:

Type	Accuracy
HP 5016, opt. 004	$\pm 7 \times 10^{-12}$
HP 5061B	$\pm 1 \times 10^{-11}$

and, for round trip (propagation) times  $T$  between 10 and 100 ms, the effect of the absolute accuracy of the oscillator frequency can be neglected.

However, over short time intervals (on the order of the round trip propagation time), the oscillator is more accurate than pure: that is, the noise affecting the output signal is higher than the inherent inaccuracy of the oscillator, and this is to be considered as a source of errors.

The short term frequency instability of the oscillator translates directly into a contribution to the observed scatter of the ranging data around a mean value (ranging noise): this has been computed, by using the Allan variance  $\sigma_y(\tau)$  as a measure of the frequency stability of the oscillator, and the results are presented in table I.

The Option 004 (high stability) Cesium standard used in the GLTN satisfies the requirements for millimeter ranging accuracy for round trip times less than 100 ms (see fig. 1); the regular HP5061B cesium tube is the noisiest. Rubidium standards are better than even the option 004 Cesium for measurement times up to a hundred seconds, then they quickly degrade as the effects of frequency drift and random walk become apparent. We are considering (and testing) other types of oscillators, such as the new BVA XTAL oscillator, to provide a stable frequency source for ranging applications.

However, other requirements must be taken into account: to correlate ranging measurements taken at different stations, the data is time-tagged at each site with reference to the local time scale. Each station time scale is referenced to a common time scale, that is UTC(USNO), by using different time transfer techniques.

Any error in time synchronization between two sites translates directly into an error in time-tagging the data, that is, an error in correlating measurements taken at different sites. Ranging measurements are not affected directly by this error, but the ranging data processing for computing the baselines is affected.

The current GLTN synchronization requirements limit the time position error versus UTC(USNO) to less than  $\pm 1$  microsecond to achieve sub-centimeter accuracy in the computation of the baselines, but we are working to improve the present performance to a few hundred nanoseconds for the full network in the near future.

#### LASER TRACKING STATIONS TIMING SUBSYSTEM

The timing subsystem of a typical Laser Ranging Station (LRS) is intended to provide:

- a) - a low phase noise, highly stable and accurate oscillator to support the ranging measurements, i.e. to precisely measure the time of flight of the light pulse travelling from the Laser station to the satellite and back;
- b) - a reliable, long-term-stable time base, to time tag the ranging measurements, with the purpose of correlating measurements taken at different stations. This time base is referenced to UTC(USNO).

Several configurations of the LRS's are currently in operation within the GLTN; these can be subdivided into three main categories:

- 1) - old LRS's, such as MOBLAS-2 or MOBLAS-3, which will be either phased out or refurbished in the near future;
- 2) - MOBLAS-4 to MOBLAS-8;
- 3) - Transportable LRS's, or TLRs stations.

#### *TIMING SUBSYSTEM: MOBLAS-4 to MOBLAS-8*

Fig. 2 shows a typical configuration for a LRS timing subsystem (LRSTS) before the introduction of GPS timing receivers in the GLTN. The LRSTS generates the timing signals used throughout the Laser ranging system. The signals generated are the station on-time 1 PPS (Pulse per Second) clock signal, a 10 kPPS signal, BCD and binary parallel time codes and coherent 5 MHz and 1 MHz sine wave signals.

The LRSTS is mounted in a 19-inch equipment rack, and consists of a time code generator (TCG), time interval counter (TIC), oscilloscope, WWV and LORAN-C timing receivers, recorders, distribution amplifier, the Cesium Beam frequency standard, a BCD-to-binary code converter and a stand-by power supply to provide uninterruptible power to the standard in the event of a power failure.

The primary frequency standard for the LRSTS is the HP model 5061A (opt. 004) cesium beam oscillator: the outputs of the frequency standard are used as reference signals to drive the TCG, the LORAN-C receiver and other equipment via the distribution amplifier. The WWV timing receiver was used for the coarse synchronization of the LRSTS, to set the Austron Model 2005 LORAN-C timing receiver, that was the primary means of referencing the station time back to UTC(USNO) prior to the introduction of GPS (Global Positioning System) timing receivers.

In most systems, a GPS timing receiver has been substituted for the LORAN-C timing receiver in the LRSTS, and the configuration changed as in fig. 3: the WWV receiver, oscilloscope and strip-chart recorders were no longer needed. The GPS receiver (FTS model 8400) monitors the 1 PPS clock from the Cesium standard. Since the station time is derived from the TCG, which can be offset from the Cesium 1 PPS reference, the TIC is used to monitor the Cesium 1 PPS time versus the station time as given by the TCG.

#### *TIMING SUBSYSTEM: TLRS-3 and TLRS-4*

The LRS configuration for TLRS-3 and -4 is simplified compared to the MOBILAS LRSs, and also the timing subsystem is simpler (fig. 4). No serial or parallel time codes are used, since the Time of Year (TOY) is generated directly within the computer system by a built-in clock; the timing subsystem simply provides the reference frequency (5 MHz) to the computer clock, and the 1 PPS synchronization signal to set it.

The primary reference oscillator is the HP5061B (opt. 004) Cesium beam frequency standard; the GPS timing receiver (STI 502) monitors the 1 PPS from the Cesium frequency standard.

A steerable time code generator generates the station time (1 PPS on-time signal): this is fed to the computer and compared, via a time interval counter, with the 1 PPS generated by the primary frequency standard.

#### **SYNCHRONIZATION**

Two techniques have been used in the past and are currently used within the GLTN to precisely synchronize remote clocks:

- \* Portable clock trips, providing a time transfer accuracy estimated to be within 50 to 100 ns;
- \* Synchronization via GPS timing receivers, currently providing global time transfer to better than a few hundreds of nanoseconds, but with an expected accuracy between 20 and 100 ns if used in the "common view" mode. This mode is not currently used in the network because of operational constraints, but we are working to introduce it, since we expect a marked improvement in the quality of the data to match the future requirements for GTLN.

Older LORAN-C timing receivers, providing synchronization on the order of 1 to 10 microseconds, are being phased out from the GLTN stations; they do not provide the required accuracy, especially when used in remote areas where they have to rely on the skywave mode of propagation.

#### **DATA COLLECTION AND PROCESSING**

GPS and LORAN-C time position measurements are made daily at the GLTN stations. Each station equipped with a GPS timing receiver collects GPS data twice a day for each visible satellite. The raw time position reading is recorded during the 10-minute long satellite observation pass, and it is usually taken at the 6-th minute, elapsed time, since

the start epoch of the observation. Time, date and satellite vehicle number are recorded for each measurement in addition to the timing data.

The LORAN-C data is collected once a day (as a single measurement of the "Station - LORAN" time difference) only at those LTN stations not equipped with GPS timing receivers.

The measurements (see fig. 5) are then transmitted (via TWX or satellite links, where available) to the Bendix LTN Communication Center, and are stored in the daily Laser Operations Report (LOR). Also transmitted in the LOR is information concerning station time steps, frequency changes, power outages, equipment problems, etc.

At BFEC, all the LTN timing data, i.e. LORAN-C and GPS, is analyzed for time position using the PTS Automated Time Position (ATP) Program. The function of the ATP Program is to provide:

- daily time position determination;
- calculate long term Cesium frequency offset;
- predict the date that station tolerances will exceed 1 microsecond (for the present requirements);
- evaluate the validity of the data and data analysis methods.

The Bendix ATP system includes several computer programs that:

- read the LOR data into the ATP data base;
- permit the manual entry, editing, deletion and listing of data files;
- perform analysis of the timing measurements.

The system is coded in FORTRAN and runs on the Bendix VAX computer system (two VAX 11/780s and one VAX 8600 computers).

The LTN timing data is loaded into the ATP database via the Automatic LOR Reader section of the ATP program. Before the analysis can begin, LORAN-C phase values must be entered into the ATP database as required. Only when all the necessary data is stored, time position analysis can be accomplished by using the Data Analysis section of the ATP program.

The Data Analysis section is divided into two subsections, which perform different processing on LORAN-C and GPS data; the selection of which subsection is used depends upon a particular station timing reference. Currently, MOBLAS-7 has a LORAN-C receiver as its timing reference, while Arequipa, Matera, Haleakala, Orroral, McDonald and MOBLAS-2, -4, -5, -6 and -8 use GPS. TLRS-1 through -4 also use GPS receivers as their timing references.

Least squares fitting is the mathematical method used to determine the time position of the station timing system, with the resulting correlation coefficient as the confidence determining factor. Both observed and computed time positions are provided as the output of the data analysis program. Normally, a 92-day long time frame provides the database length required to determine the time position. Reported frequency changes during this period cause the analysis program to break the analysis into smaller segments.

## **DATA ANALYSIS**

The data collected at Arequipa at the beginning of this year (fig. 6), referencing the ARQ

clock to GPS-12, is a good example of problems arising in the analysis of timing data. In the plot, the dots represent the data collected at the station and the asterisks the result of the least squares fitting process. The time position of the clock is based on the fitted line, computed at the same time the measured data was taken.

The plot shows that around February 1st and during the first week of February the data had a sudden jump of about 700 ns, then continued drifting at the same rate (this means that the frequency of the clock was not affected by the jump in phase) until the middle of February.

Then, very probably, a frequency change took place, for the slope of the data changed from then on; at the beginning of March a time step was introduced via the station TCG (Time Code Generator), but this was properly taken into account by the analysis program.

Two non-random effects can be immediately identified in the data:

- \* a phase (time) jump;
- \* a frequency change.

In addition, two outliers are evident in the data collected at the beginning and at the end of March.

The correct procedure we are introducing to analyze correctly the data is:

- 1) - Identify the systematic effects first!
- 2) - Run the fitting program on the data sets [a] and [b] (see fig. 6) separately; this will produce two independent fits of the type:

$$(4) \quad Y = a(1) * X + b(1) \quad \text{for the data set [a]}$$

$$(5) \quad Y = a(2) * X + b(2) \quad \text{for the data set [b]}$$

where  $a(1)$  shall be identical (in a statistical sense!) to  $a(2)$  since the slope is the same.

- 3) - Now estimate the magnitude of the time jump; one technique may proceed as follows: compute  $Y$  at a convenient point  $x$  between [a] and [b] by using the two fits:

$$y(1) = a(1) * x + b(1) \quad \text{using eq. (4)}$$

$$y(2) = a(2) * x + b(2) \quad \text{using eq. (5)}$$

The time jump magnitude will be:

$$DY = y(2) - y(1)$$

- 4) - Now, it will be possible to correct the data set [a] (or [b]) for  $DY$ , and fit the joint [a + b] data set with a single fit, to obtain the best estimate for the slope during the full period in which the frequency of the clock did not change:

$$Y = a(3) * X + b(3) \quad \text{for the data set [a + b]}$$

However, it may still be convenient to use eq. (4) and eq. (5) to obtain the time position of the clock within the period covered by the data set [a] or [b] respectively.

- 5) - Then, the linear fit is applied to the data in [c], after removing the two outliers using some suitable filtering technique, and the results are the time position and the frequency of the station clock for the period [c] and for future predictions:

$$Y = a(4) * X + b(4)$$

Now, it is possible to estimate the frequency change of the clock as:

$$DF = a(4) - a(3)$$

### CONTINUING DEVELOPMENTS AND FUTURE WORK

Work is in progress at BFEC to improve our data processing capability through a more efficient use of our computer resources and by development and testing of new algorithms and procedures for data processing and analysis.

We are currently working on new methods and techniques to perform an automatic identification and flagging of anomalies in the data which may indicate a change in the behaviour of the clock; in particular, we are trying to test and implement algorithms for automatic detection of:

- o - outliers in the data;
- o - phase (time) jumps;
- o - changes in the frequency of the clock.

Several techniques are available, and some have already been implemented and in use at BFEC; after testing, which will include an assessment of the behavior of the proposed algorithms in an operational environment, the routines will be incorporated into the ATP program, to handle the anomalies automatically, with little or no operation intervention.

Techniques which are presently used and developed include filter algorithms based on iterative rejection of outliers, correlation analysis and analysis of the variance of the fit and analysis of the variance of the computed coefficients for the fitted polynomial.

In addition, we are working to include a fully automatic Data Acquisition and Communication System (DACS) as a part of the Timing Subsystem for the LRSs. The DACS would automatically collect timing data at the LRSs with little operator intervention.

This will help to minimize the communication errors and improve the data collection capability within the GLTN, in terms of increasing the rate and the number of data points collected at each site. Moreover, by applying preliminary data reduction techniques directly at the remote site, this will reduce the number of data exchanged while effectively increasing the quantity of data collected and used in the process of time position and frequency estimation.

### CONCLUSIONS

The Precision Timing Section (PTS) at BFEC has been responsible for maintaining and reporting time positions for the Goddard Laser Tracking Network (GLTN) for the past twelve years. In the past, GLTN's stringent timing requirements have necessitated the development and utilization of advanced time transfer and timing data processing techniques: the GLTN pioneered the development and operational use of GPS timing receivers

for time transfer. Still new timing methods are being developed and tested by PTS to increase BFEC's capabilities in the measurement and transfer of precise time, in close cooperation with NASA and other U.S. government agencies.

#### REFERENCES

- 1) V. S. Reinhardt, FREQUENCY STABILITY REQUIREMENTS FOR TWO-WAY RANGE RATE TRACKING, NASA-GSFC Document X-814-75-315 (December 1975)
- 2) Hewlett-Packard, 1987 PRODUCT CATALOG, pp. 338-340
- 3) E. Detoma, FINAL REPORT FOR THE LASER TRACKING NETWORK: TIME AND FREQUENCY STUDY, Bendix Field Engineering Corporation Report, NASA Contract NAS5-28027 (October 1987)



TABLE I  
RANGE STABILITY vs. CLOCK TYPE

Standard	T [s]	$\sigma_y(T)$	$\sigma_s(T)$ [mm]	$\sigma_s^*(T, T)$ [mm]
Cs HP5061B opt 004	0.01	1.5 10 exp(-10)	.225	
	0.1	1.5 10 exp(-11)	.225	
	1	5 10 exp(-12)	.75	.411
	10	2.7 10 exp(-13)	4.05	.701
	100	8.5 10 exp(-13)	12.75	.698
	1000	2.7 10 exp(-13)	40.5	.701
Cs HP5061	0.01	1.5 10 exp(-10)	.225	
	0.1	5.6 10 exp(-11)	.84	
	1	5.6 10 exp(-12)	8.40	4.6
	10	2.6 10 exp(-12)	37.5	6.49
	100	8 10 exp(-13)	120	6.57
	1000	2.5 10 exp(-13)	375	6.49
Rb HP5065	0.01	1.5 10 exp(-10)	.225	
	0.1	1.5 10 exp(-11)	.225	
	1	5. 10 exp(-12)	.75	.411
	10	1.6 10 exp(-12)	2.4	.415
	100	5 10 exp(-13)	7.5	.410
	1000	5 10 exp(-13)	75	1.299
XTAL HP105B	0.01	1.5 10 exp(-10)	.225	
	.1	1.5 10 exp(-11)	.225	
	1	5 10 exp(-12)	.75	.411

NOTES: T - integration time (seconds)  
 $\sigma_y(T)$  - stability of the clock  
 $\sigma_s(T)$  - precision of the range measurements (mm)  
 $\sigma_s^*(T, T)$  - precision of the average of range  
measurements (T = 0.3 s)

Figure 1

# RANGE STABILITY

vs. CLOCK TYPE

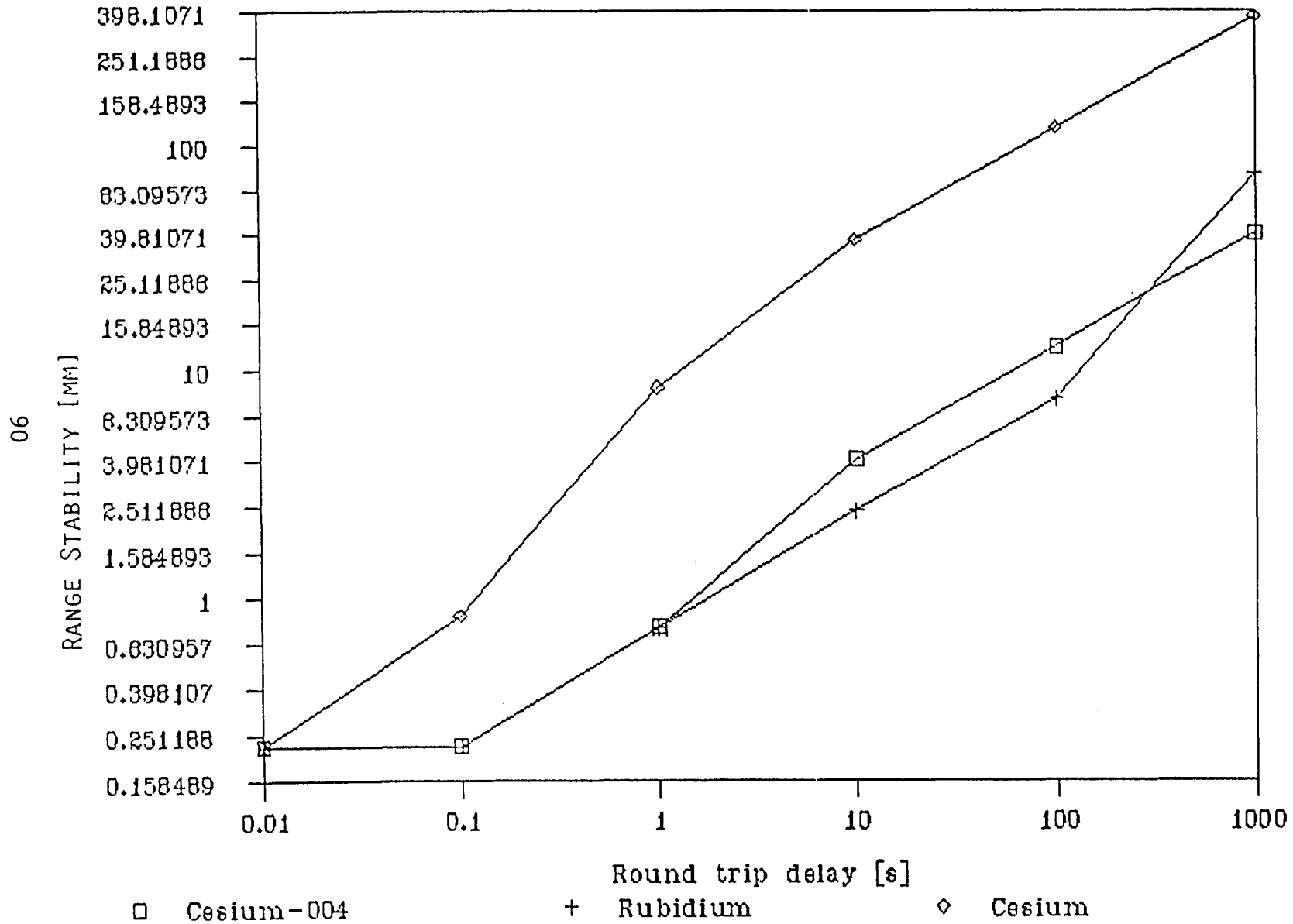

Figure 2 - Typical Laser Ranging System Timing Subsystem  
 Block Diagram - Configuration with LORAN-C Timing Receiver  
 (from MH-1164)

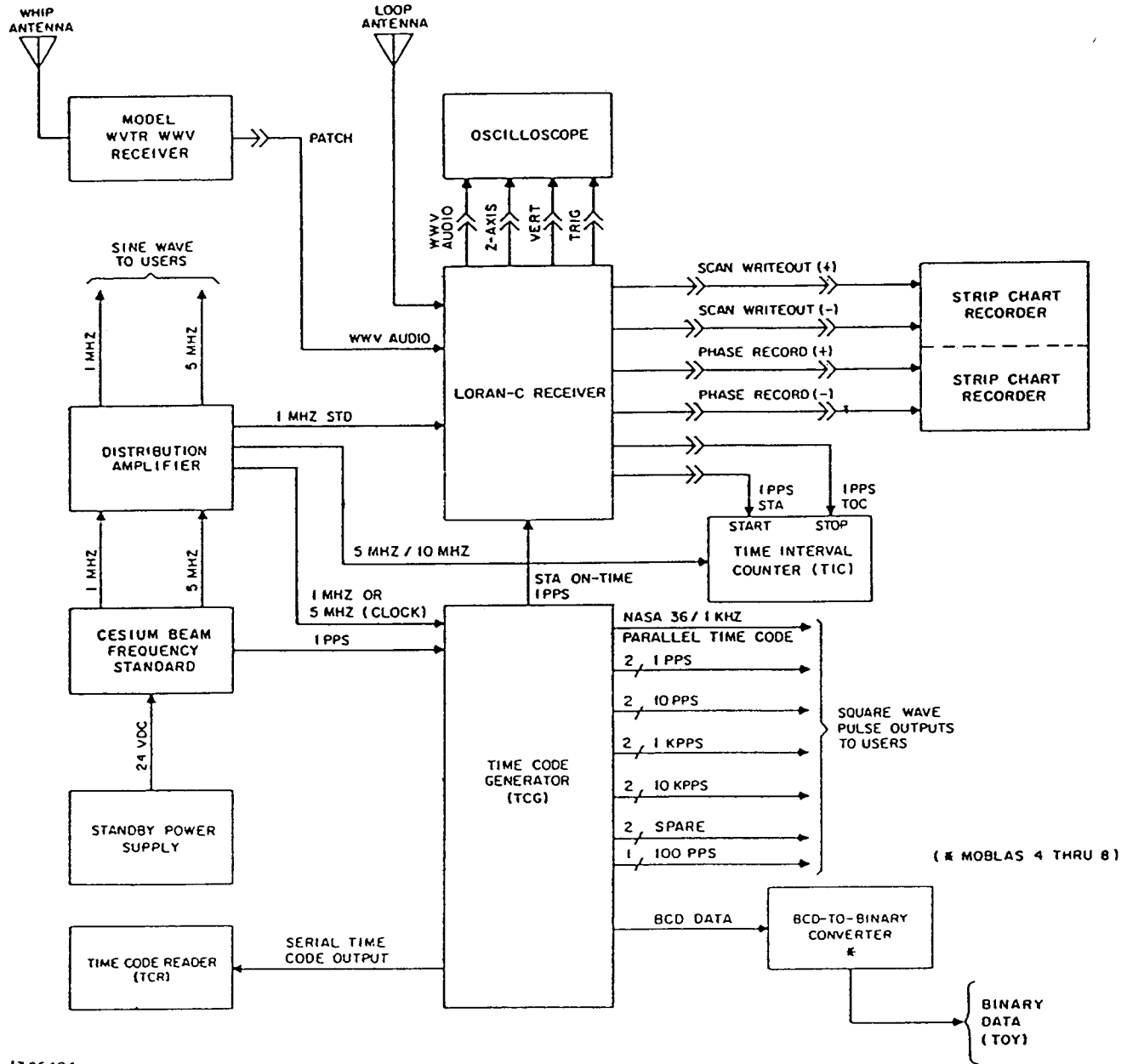
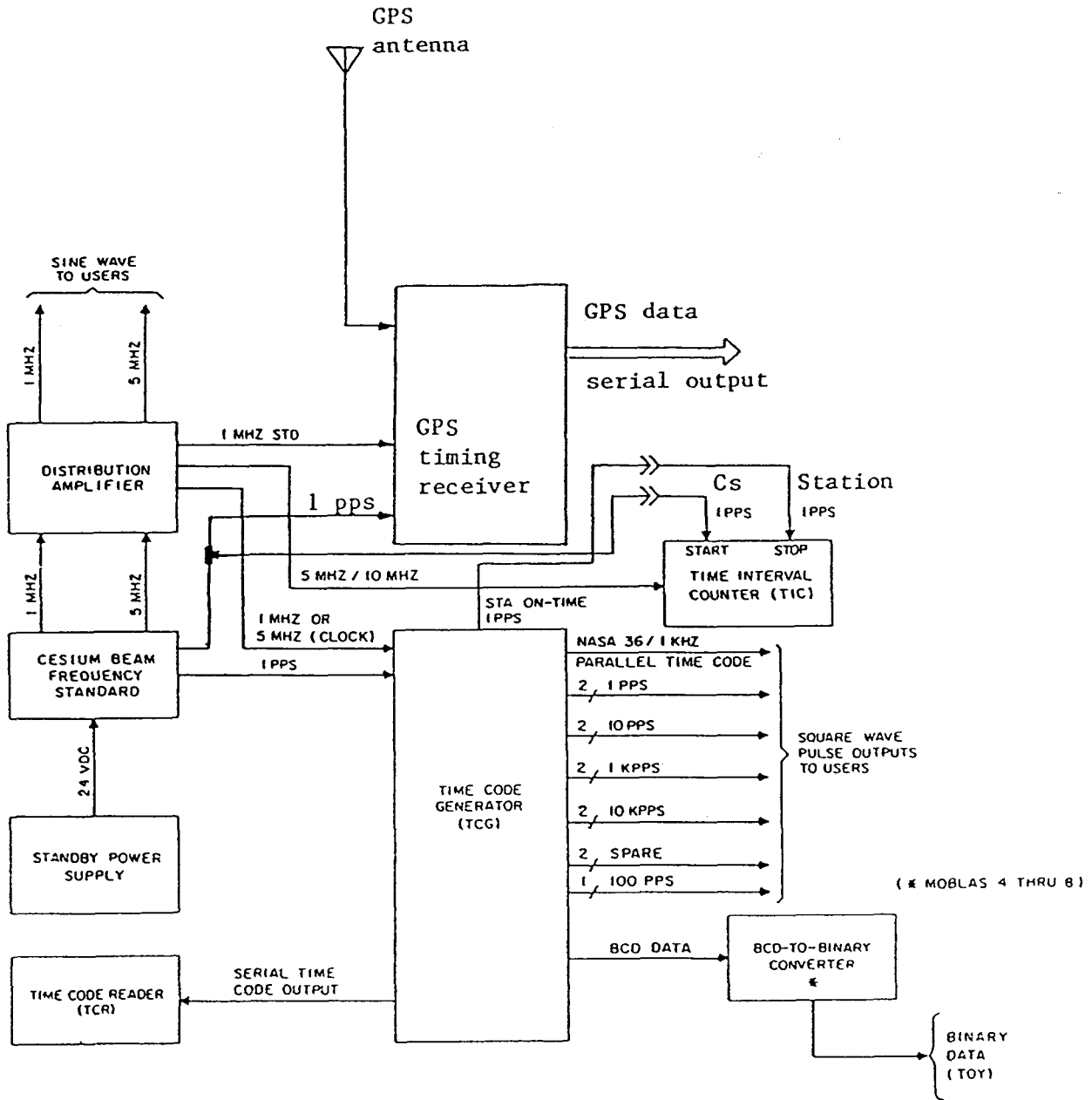

Figure 3 - Typical Laser Ranging System Timing Subsystem  
 Block Diagram - Configuration with GPS timing receiver



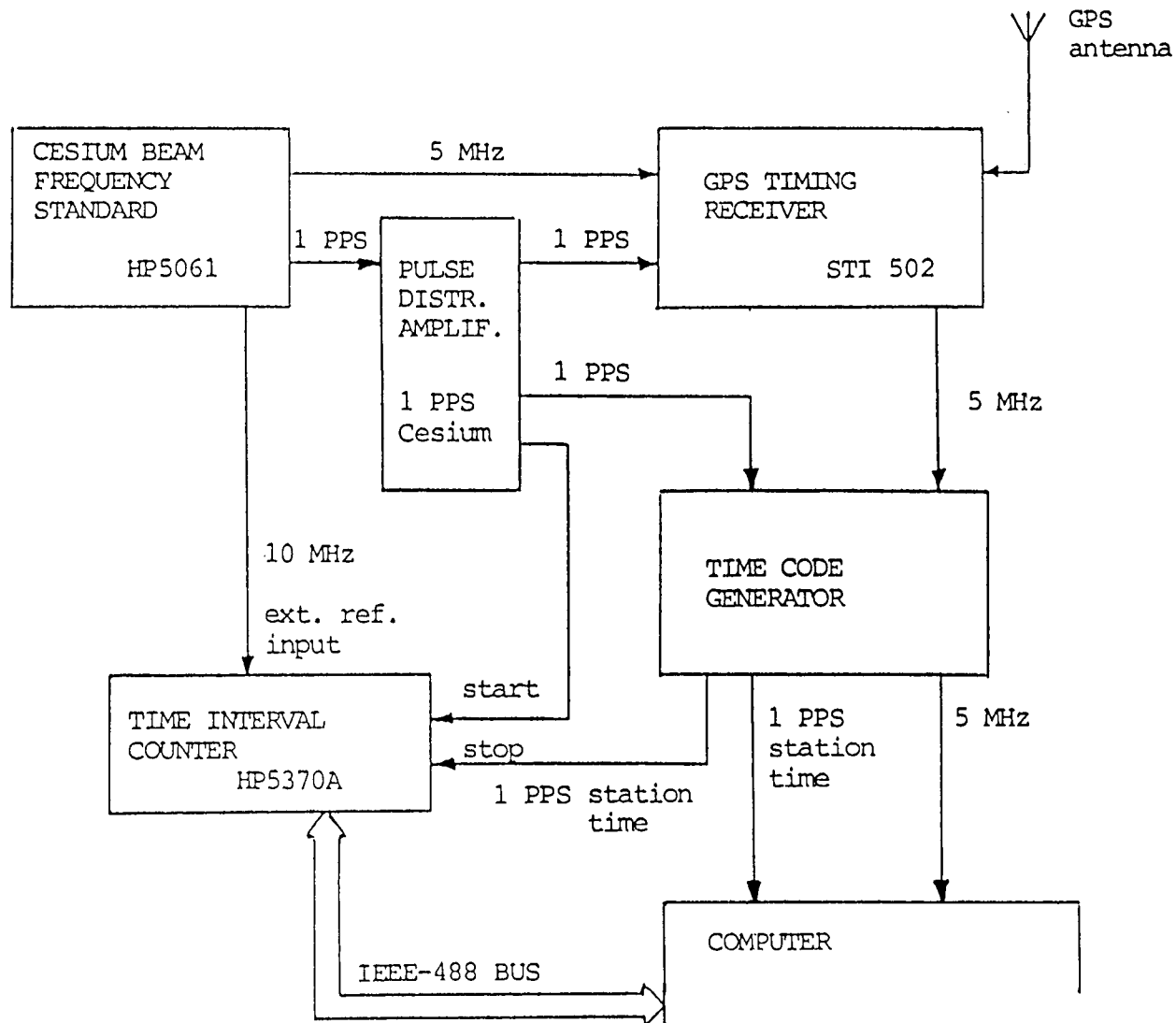

Figure 4 - TIMING SUBSYSTEM BLOCK DIAGRAM  
TLRS-3 and TLRS-4  
Alternate configuration

FUNCTIONS

READ LASER OPERATIONS REPORT (LOR)  
DATA ANALYSIS AND REPORTING  
FILE MANAGEMENT

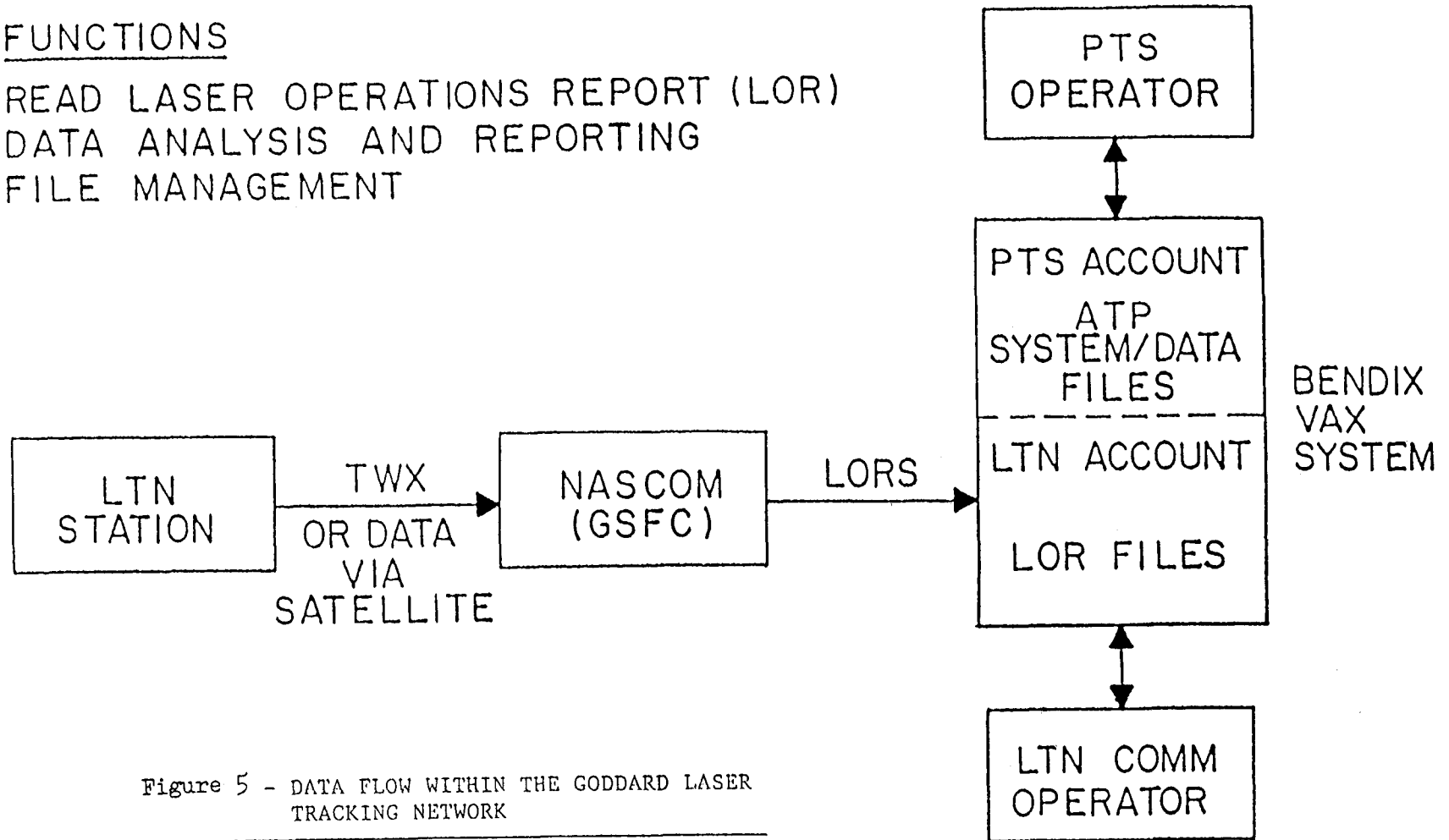

Figure 5 - DATA FLOW WITHIN THE GODDARD LASER TRACKING NETWORK

DATE : 7-APR-87

TIME : 16:39:41

ARQ Referenced to SV 12

NANOSECONDS

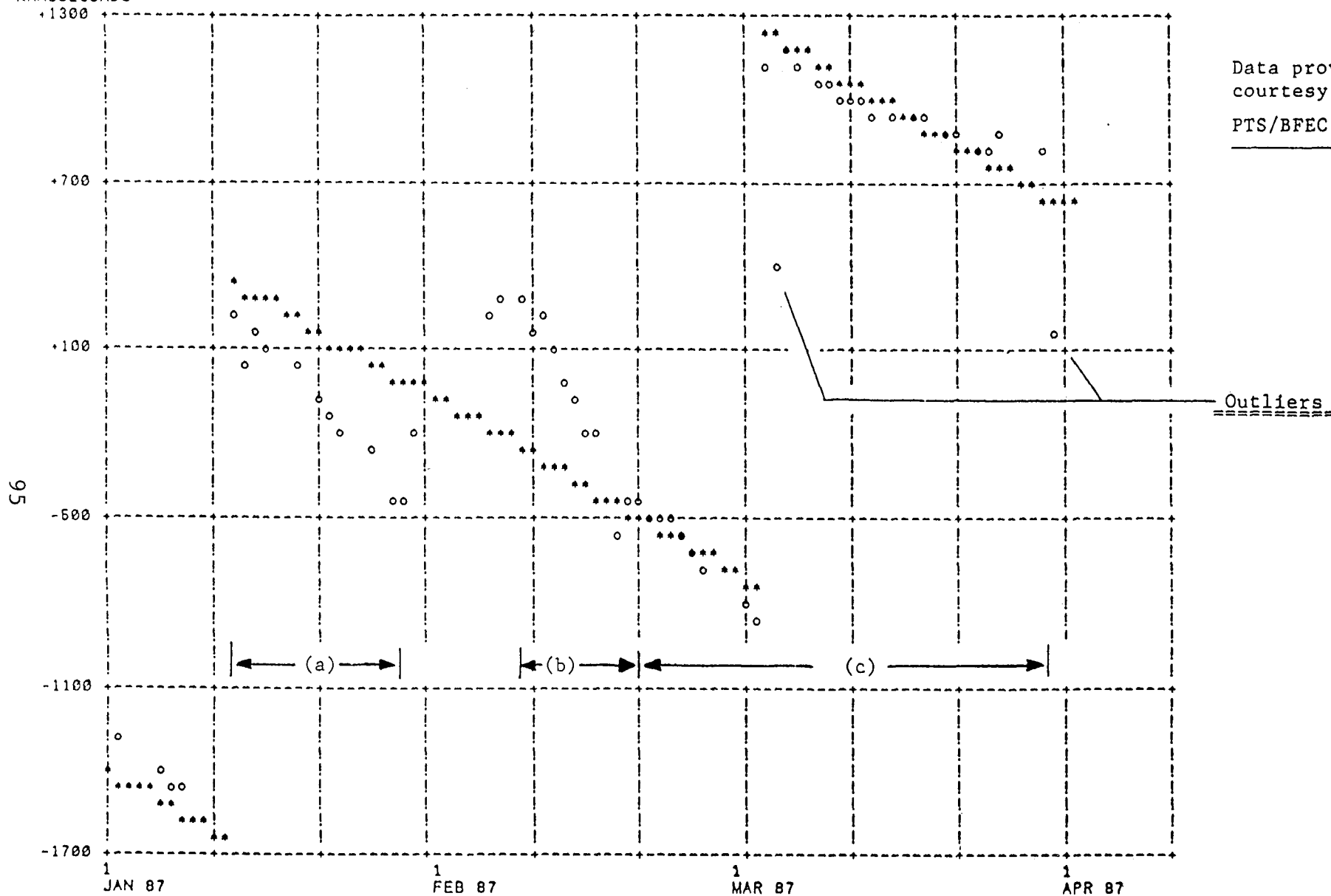

Data provided  
courtesy of:  
PTS/BFEC

LEGEND

o - Raw Data

\* - Calculated Data

Figure 6 - EXAMPLE OF TIMING DATA (From ARQ, 1987)